

RGV

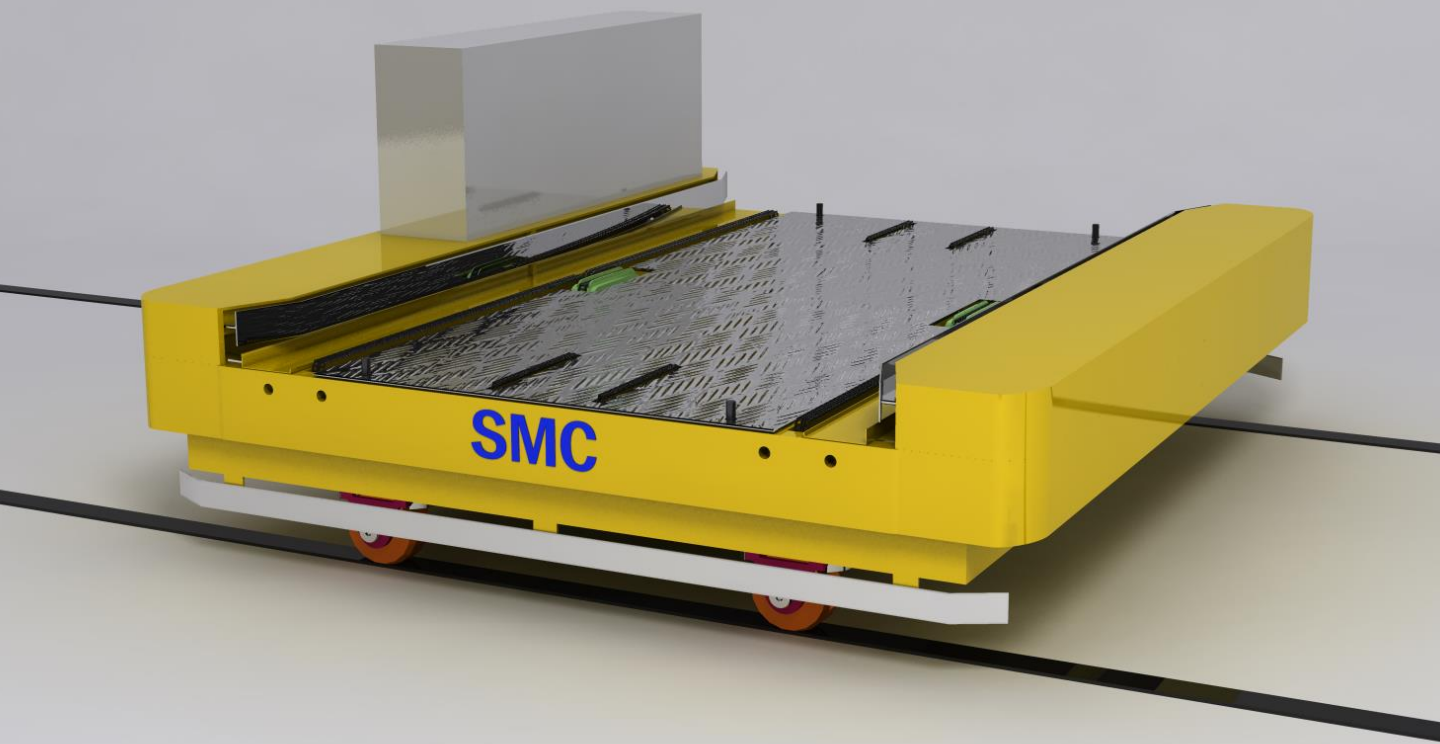

RGV can be used in combination with various navigation

RGV(Rail Guided Vehicle)

Rail Guided Vehicle is a fast and flexible material transporting system with separate input/output stations that allow RGV to perform multiple performances at once. SMC offers linear and loop types of RGVs, which runs safely and smoothly at high speed, to provide maximized performance for customer's needs.

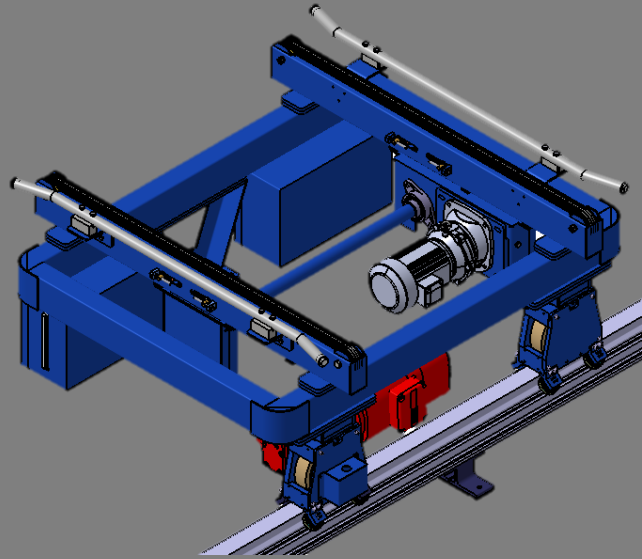

Benefit

- ✓ Efficiency achieved by automatically controlled material flow
- ✓ Can be used in combination with various navigation
- ✓ Simplified layout with controlled distribution
- ✓ Frequent update on vehicle position and short dead-reckoning distances.
- ✓ Independent operation by individual controller
- ✓ Heavy weight lifting capability with subdued noise & vibration

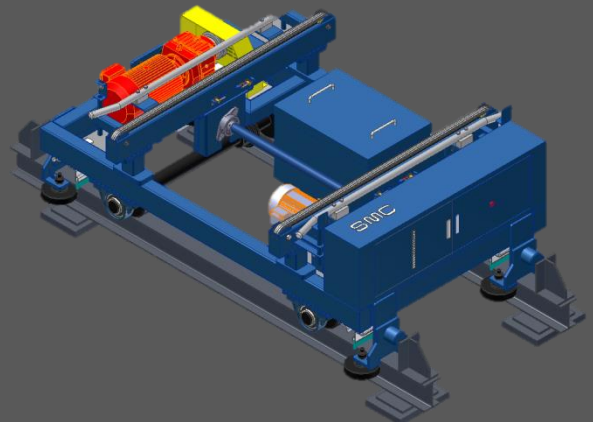
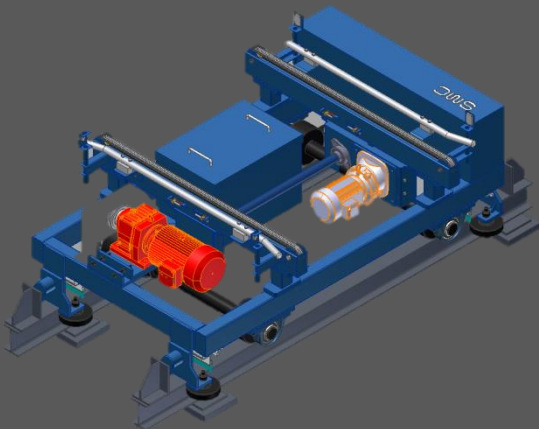

Type

RGV type classified by Rail & Speed

> Shuttle Type(Linear Type)



Linear Type

- ✓ Traveling speed: Max. 270m/min
- ✓ Loading speed: Max.10~35 m/min
- ✓ Controller: SMC5000 or PLC
- ✓ Speed control: Inverter

The high-speed linear type is an advanced RGV that maintains stable control through the inverter. Low error rates due to simple system configuration, easy to maintain

> Loop type



Loop Type

- ✓ Traveling speed: Max. 200m/min
- ✓ Loading speed: Max.10~35 m/min
- ✓ Controller: SMC5000 or PLC
- ✓ Speed control: Inverter

Loop-type RGV can be used to escape from existing complex line conveyor systems, with curves, flexible path design and vehicle addition to increased throughput